



#### ULMA SUBSIDIARIES

**ARGENTINA**  
**ULMA Packaging, S.A.**  
 Avda. 101 - Iturraspe 10 75  
 General. San Martín (B1650ICC)  
 Provincia de Buenos Aires (Rep. Argentina)  
 Tel.: +54 (11) 47 13 83 75  
 Fax: +54 (11) 47 55 39 83  
 e-mail: ulmapackaging@ulmapackaging.com.ar

**AUSTRALIA**  
**ULMA Packaging (Australia) Pty Ltd**  
 9 Archimedes Place Muragrie  
 P. O. Box 394 Brisbane QLD 4171  
 AUSTRALIA  
 Tel.: +61 (07) 3399 4922  
 Fax: +61 (07) 3399 4688  
 e-mail: info@ulmapackaging.com.au

**BRASIL**  
**ULMA Packaging Ltda.**  
 Rua Álvaro Rodrigues, nº 429 / 449  
 Brooklin  
 04582-000-SÃO PAULO-SP (Brasil)  
 Tel.: +55 (011) 5092 6060  
 Fax: +55 (011) 5092 6059  
 e-mail: ulma@packaging-ulma.com.br

**FRANCE**  
**ULMA Packaging S.A.R.L.**  
 Centre Erika - Z.I. Jalday  
 64500 SAINT JEAN DE LUZ (France)  
 Tel.: +33 (0) 559 08 07 07  
 Fax: +33 (0) 559 08 07 00  
 e-mail: info@ulmapackaging.fr

**GERMANY**  
**ULMA Packaging GmbH.**  
 Torfstelle, 10  
 21217 SEEVETAL (Germany)  
 Tel.: +49 (0) 40 702 923-3  
 Fax: +49 (0) 40 702 923-45  
 e-mail: info@ulma-packaging.de

**HOLLAND**  
**ULMA Packaging B.V.**  
 Techniekweg 19 A  
 4143 HW LEERDAM (The Netherlands)  
 Tel.: +31 (0) 345 623800  
 Fax: +31 (0) 345 623918  
 e-mail: info@ulmapackaging.nl

**ITALY**  
**ULMA Packaging srl**  
 Strada al Rio Chiappone, 1  
 Angolo Via Emilia Pavese  
 29100 PIACENZA (Italy)  
 Tel.: +39 0523 400 800  
 Fax: +39 0523 400 801  
 e-mail: info@ulmapackaging.it

**MÉXICO**  
**ULMA Packaging S.A. de C.V.**  
 Via Gustavo Baz nº 305  
 Col. La Loma Tlalnepantla  
 C.P.54060 Edo. de México (México)  
 Tel.: +52 - 5365 80 72  
 Fax: +52 - 5365 80 75  
 e-mail: info@ulmapackaging.com.mx

**SOUTH AFRICA**  
**ULMA Packaging Systems (SA) (Pty) Ltd**  
 Village Crescent, Linbro Village  
 LINBRO PARK, SANDTON (South Africa)  
 Tel.: +27 (11) 608 40 05 / 06  
 Fax: +27 (11) 608 40 77  
 e-mail: sales@ulmapackaging.co.za

**UK**  
**ULMA Packaging Ltd**  
 Unit 4, Woodland Court  
 Coach Crescent, Shireoaks  
 Worksop Nottinghamshire, S81 8AD (UK)  
 Tel.: +44 (0) 1909 506 504  
 Fax: +44 (0) 1909 506 509  
 e-mail: info@ulmapackaging.co.uk

**USA**  
**ULMA Packaging Systems, Inc.**  
 3035 Torrington Drive  
 Ball Ground, GA 30107 (USA)  
 Tel.: +1 (770) 345-5300  
 Fax: +1 (770) 345-5322  
 e-mail: info@ulmapackaging.us

**POLAND**  
**ULMA Packaging Polska Sp. z o.o.**  
 Ul. Sikorskiego 5  
 05-119 - Legionowo (Poland)  
 Tel.: +48 (22) 357 8438  
 Fax: +48 (22) 774 4368  
 e-mail: biuro@ulmapackaging.pl

#### DELEGACIONES ULMA

**DELEGACIÓN ANDALUCÍA**  
 Polígono Fridex  
 Autovía Sevilla - Málaga Km.4,2  
 41500 ALCALA DE GUADAIRA (Sevilla)  
 Tel.: 95 - 563 00 15  
 Fax: 95 - 563 00 17  
 e-mail: andalucia@ulmapackaging.com

**DELEGACIÓN CANARIAS**  
 Camino de las Gaviyas, 131  
 38204 LA LAGUNA (Tenerife)  
 Tel.: 922 - 31 44 47  
 Fax: 922 - 31 58 10  
 e-mail: canarias@ulmapackaging.com

**DELEGACIÓN CATALUNYA**  
 C/ Pintor Velázquez, 7-9  
 08213 POLINYA (Barcelona)  
 Tel.: 93 - 713 28 45  
 Fax: 93 - 713 35 57  
 e-mail: catalunya@ulmapackaging.com

**DELEGACIÓN CENTRO**  
 Avda. Cerro del Águila, 3  
 Parque Empresarial SANSE - Edificio 2 Of. 2-B1  
 28700 S.S DE LOS REYES (Madrid)  
 Tel.: 91 - 652 37 00  
 Fax: 91 - 652 88 92  
 e-mail: centro@ulmapackaging.com

**DELEGACIÓN GALICIA**  
 Avda. de Madrid, 73-2º, Oficina 9  
 36214 VIGO (Pontevedra)  
 Tel.: 986 - 23 15 30  
 Fax: 986 - 23 21 06  
 e-mail: galicia@ulmapackaging.com

**DELEGACIÓN LEVANTE**  
 Edificio Parque Albufera  
 Plz. Alquería de la Culla 4, Planta 9, Ofic. 904  
 46910 ALFAFAR (Valencia)  
 Tel.: 96 - 122 52 02  
 Fax: 96 - 122 52 10  
 e-mail: levante@ulmapackaging.com

**DELEGACIÓN NORTE**  
 Barrio Garibai 28  
 Apdo. 145  
 20560 OÑATI (Gipuzkoa)  
 Tel.: 943 - 73 92 11  
 Fax: 943 - 78 32 18  
 e-mail: norte@ulmapackaging.com

Qualified agents operate in countries not listed here, contact:

LOCAL SALES AND SERVICE



**ULMA C y E, S. Coop.**

Bº Garibai, 28 - Apdo. 145  
 20.560 OÑATI (Gipuzkoa) SPAIN  
 Tel.: +34 - 943 73 92 00  
 Fax: +34 - 943 78 08 19  
 Web: www.ulmapackaging.com  
 e-mail: info@packaging.ulma.es

Ver. 01-2006 AZK/061140



THERMOFORMING

Mini

Packaging



# Mini

## Automatic Thermoformer

The MINI Is a thermoforming machine designed to pack food non-food or medical products. The package is created directly by the machine using two rolls of film. The film may be flexible or rigid up to 300 microns /12 mills. Vacuum with gas flushing is available as an option.

The MINI Series offers the ideal way to advance from manual packaging to automatic packaging. These machines provide an economical solution with the same cost saving advantages of larger thermoforming machines:

- Reduced Package Cost
- Increased Productivity
- Improved Product Appearance
- Faster Product Loading

The machine characteristics make it highly desirable for mixed production requirements, Since formats can be easily changed to meet the needs of the customer.

Its versatility, easy operation, and quick size change also make it suitable as a support machine for short run products.

Like all other ULMA Machines, the priority in design is given to:

- Highest quality components.
- Use of standard commercial high quality components.
- In accordance with international safety standards.
- Easy sanitation IP-65 compliance.
- Easy change of dies and tooling.
- Easy access for maintenance.
- Ease of operation.

### TECHNICAL SPECIFICATIONS

#### Construction Features:

- Stainless steel AISI 304.
- Programmable logic control system.
- Operational diagnostics.
- Parameters and error messages are displayed.
- Dies and tools are made of anodized aluminum.

- Conforms to international "CE" safety codes, and ISO 9001 quality standards.

#### Ease of Use and Maintenance:

- Highly efficient.
- Memorizes data for up to 50 configurations.
- Programmable advance speed.
- Minimum maintenance.

#### Optional Devices:

- Upper and lower printed film centering.
- Expanded loading area (except baby).
- Vacuum and gas flush systems.
- Integrable vacuum pump – 25, – 63, – or 100 m<sup>3</sup>/h.
- Special adaptations for clean rooms.
- Special components for very corrosive products.
- Integration with peripheral equipment.
- Hole punching systems for hanging product.
- Date coders.
- Re-closeable zipper attachment.
- Easy open options.
- Zig-zag knife for easy open package.
- Quick size change.

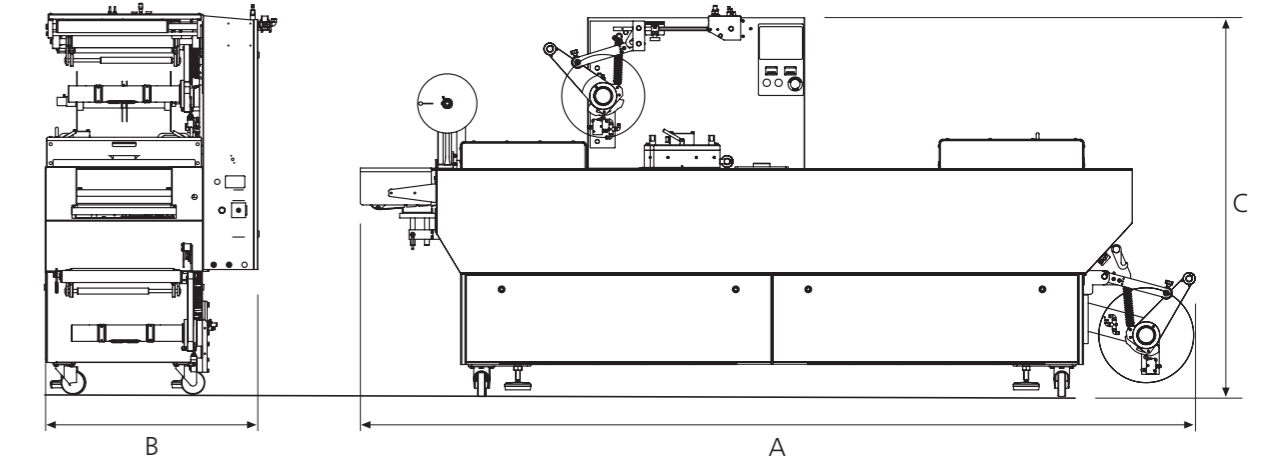

Format Change without Tools

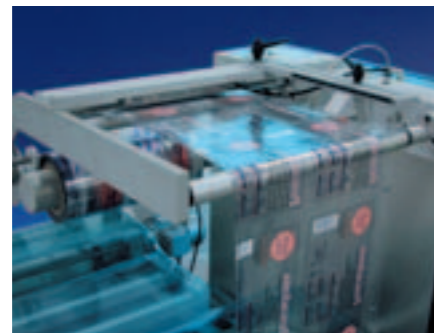

Printed Film Centering System

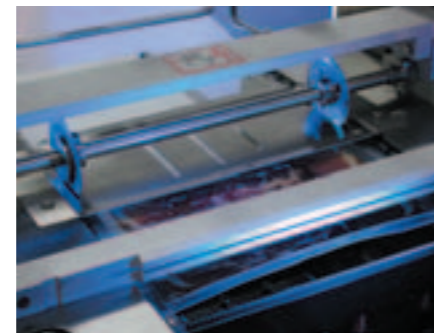

Longitudinal and Transversal cutting System (flexible film)

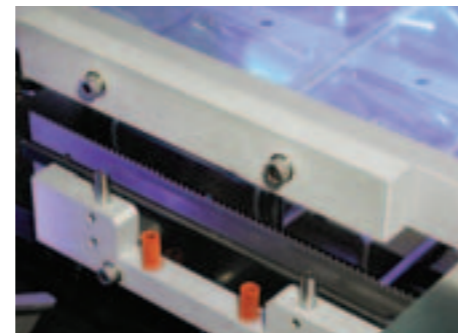

Punch System for Hanging Holes

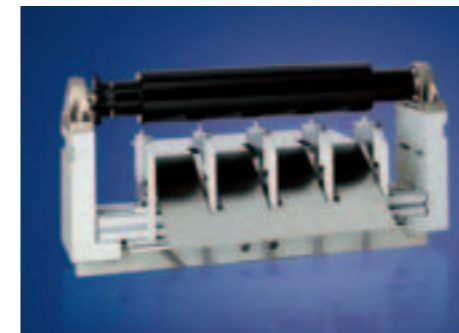

Pneumatic Longitudinal Cutting System



Integrated vacuum pump

SPECIFICATIONS/MODELS	Baby	Mini 280	Mini 320	Mini 360	Mini 420
Maximum Advance	200 mm. (7.9")	300 mm. (11.8")	300 mm. (11.8")	300 mm. (11.8")	300 mm. (11.8")
Depth Range	5 - 40 mm. (0.2" - 1.6")	5 - 80 mm. (0.2" - 3.16")	5 - 80 mm. (0.2" - 3.16")	5 - 80 mm. (0.2" - 3.16")	5 - 80 mm. (0.2" - 3.16")
Bottom Film Width (other widths under consult)	280 mm. (11.02")	280 mm. (11.02")	320 mm. (12.6")	360 mm. (14.17")	420 mm. (16.5")
Maximum Roll Diameter	Bottom Roll 350 mm. (13.8") Top Roll 350 mm. (13.8")				
Core Diameter	76 mm. - 3"	76 mm. - 3"	76 mm. - 3"	76 mm. - 3"	76 mm. - 3"
Loading Area (depending on advance)	200 - 500 mm.		400 - 875 mm. (expandable 1 m.)		
Water Consumption	60-120 l/h. / 2 bars / 8-10° C				
Electrical Specifications	Voltage 230/400 V. Trifásico ± 10% + Neutro + Tierra - 50/60 Hz				
	Consumption	4 kW - 14 Amp. / 220 V. 4 kW - 8 Amp. / 380 V	5 kW - 18 Amp. / 220 V. 5 kW - 11 Amp. / 380 V	5 kW - 18 Amp. / 220 V. 5 kW - 11 Amp. / 380 V	5 kW - 18 Amp. / 220 V. 5 kW - 11 Amp. / 380 V
Pneumatic Consumption	400-500 l/min. / 6bars	600-800 l/min. / 6bars	600-800 l/min. / 6bars	600-800 l/min. / 6bars	600-800 l/min. / 6bars
Machine Dimensions	A B C 2700 x 650 x 1610	A B C 3450 x 770 x 1610	A B C 3450 x 770 x 1610	A B C 3450 x 770 x 1610	A B C 3450 x 770 x 1610
Approximate Weight	600 kg.	800 kg.	800 kg.	800 kg.	800 kg.

ULMA reserves the right to change specifications without prior notice.